

DRIVER, TRACK AND RESULTS

DRIVER **COUNTRY** **WEATHER** AIR TEMP TRACK TEMP DRY INTERMEDIATE WET
TRACK **TRACTION** LOW MEDIUM HIGH **COMMENTS**
RACE **DATE** **QUALY POS.** **QUALY TIME** **STARTING POS.** **FINAL POS.**

FRONT SHOCK ABSORBERS		REAR
<input type="text" value="1000"/> cst	<input type="text" value="OIL"/>	<input type="text" value="1000"/> cst
<input type="text" value="Black"/>	<input type="text" value="SPRINGS"/>	<input type="text" value="Silver"/>
<input type="text" value=""/> mm	<input type="text" value=""/> REBOUND	<input type="text" value=""/> mm
N° HOLES <input type="text" value="6"/> Ø <input type="text" value="1.2"/> mm	PISTONS N° HOLES <input type="text" value="6"/> Ø <input type="text" value="1.2"/> mm	
<input checked="" type="checkbox"/> STRAIGHT <input type="checkbox"/> ANGLED	HOLES TYPE <input checked="" type="checkbox"/> STRAIGHT <input type="checkbox"/> ANGLED	
<input checked="" type="checkbox"/> BLADDER <input type="checkbox"/> EMULSION	SEAL TYPE <input checked="" type="checkbox"/> BLADDER <input type="checkbox"/> EMULSION	

ANTI-ROLL BARS

FRONT ANTI-ROLL BAR <input type="text" value="2.5"/> mm	REAR ANTI-ROLL BAR <input type="text" value="2.5"/> mm
---	--

DIFFERENTIALS

FRONT DIFF <input checked="" type="checkbox"/> HTD <input type="checkbox"/> STD	REAR DIFF <input checked="" type="checkbox"/> HTD <input type="checkbox"/> STD
<input type="text" value="40000"/> cst	<input type="text" value="30000"/> cst

GEARING

PINION <input type="text" value="16"/> Teeth	SPUR GEAR <input type="text" value="44"/> Teeth
--	---

ELECTRONICS

BATTERY

BRAND CAPACITY mAh

MOTOR

BRAND TYPE TIMING

ESC

BRAND TYPE

ELECTRONICS LAYOUTS

2S STICK BATTERIES
 2S SHORTY REARWARD BATTERIES
 2S SHORTY FORWARD BATTERIES

AERODYNAMIC CONFIGURATION

BODY BRAND & TYPE BODY POSITION mm
 WING BRAND & TYPE
 REAR DIFFUSER YES NO

FRONT TIRES	Controlled Tire	REAR
<input type="text" value="DragonRC 215016"/>	<input type="checkbox"/>	<input type="text" value="DragonRC 215016"/>
<input type="text" value="medium"/>		<input type="text" value="medium"/>
INSERTS <input type="text"/>		
WHEELS <input type="text"/>		

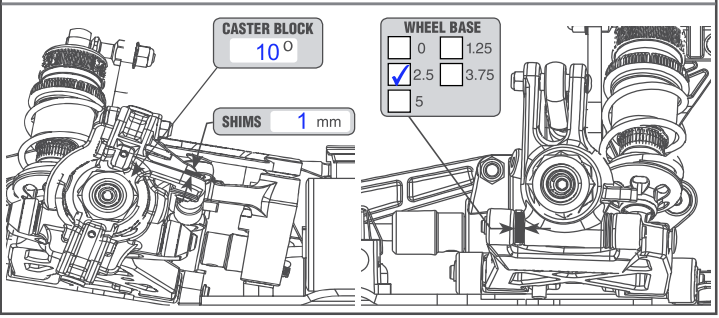
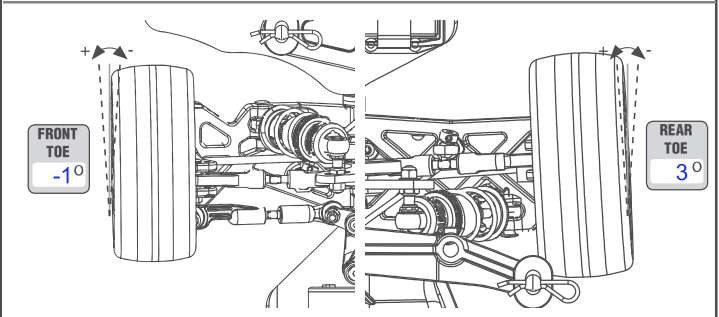
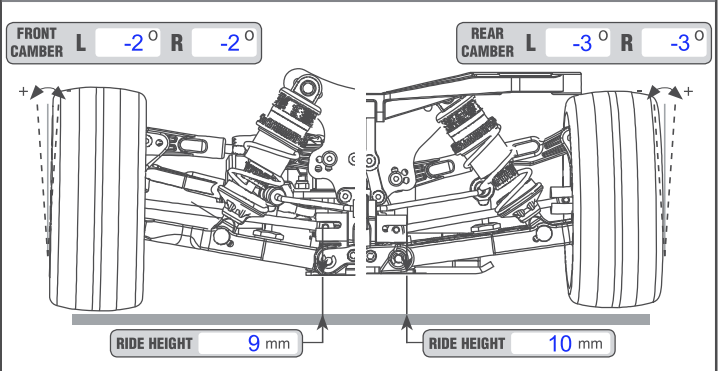
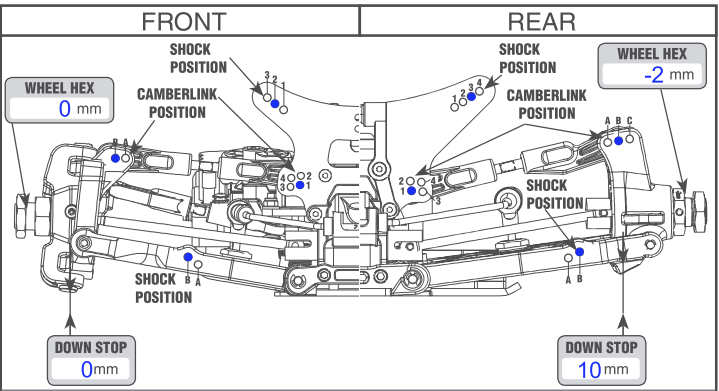

REMARKS